

# Strain Transformation

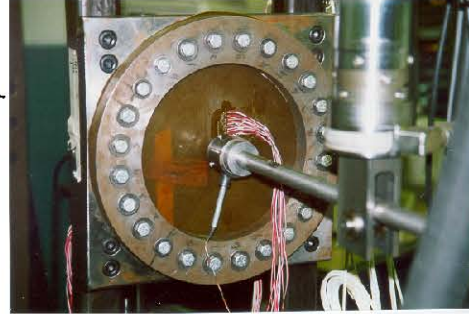
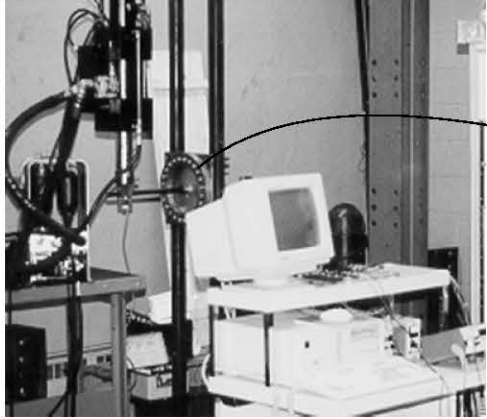

- Ideas, definitions, and equations in strain transformation are very similar to those in stress transformation. But there are also several differences.

## Learning objective

- Learn the equations and procedures of relating strains at a point in different coordinate systems.

# Line Method

## Plane Strain

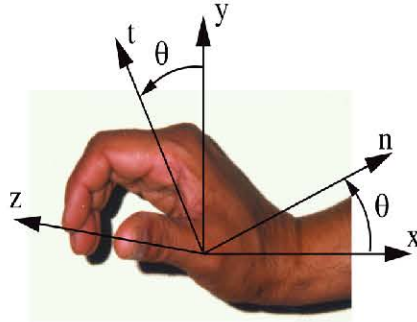

Global coordinate system is  $x, y$ , and  $z$ .

Local coordinate system is  $n, t$ , and  $z$ .

We assume  $\epsilon_{xx}$ ,  $\epsilon_{yy}$ , and  $\gamma_{xy}$  are known at a point.

Objective is to find  $\epsilon_{nn}$ ,  $\epsilon_{tt}$ , and  $\gamma_{nt}$ .

## Procedure

- Step 1 View the 'n' and 't' directions as two separate lines and determine the deformation and rotation of each line as described in steps below.
- Step 2 Construct a rectangle with a diagonal in direction of the line.
- Step 3 Relate the length of the diagonal to the lengths of the rectangle's sides.
- Step 4 Calculate deformation due to the given strain component and draw the deformed shape.
- Step 5 Find the deformation and rotation of the diagonal using small strain approximations.
- Step 6 Calculate normal strains by dividing the deformation by the length of the diagonal.
- Step 7 Calculate the change of angle from the rotation of the lines in the 'n' and 't' directions.

**C9.1** At a point, the only non-zero strain component is  $\varepsilon_{xx} = -400\mu$ . Determine the strain components in 'n' and 't' coordinate system shown.

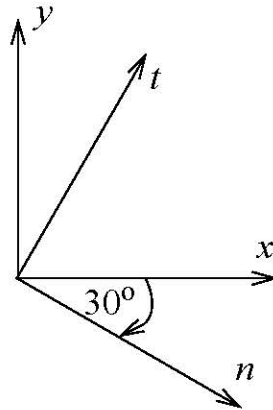

## Visualizing Principal Strain Directions

- **Principal coordinates directions** are the coordinate axes in which the shear strain is zero.
- The angles the principal axes makes with the global coordinate system are called the **principal angles**.
- Normal strains in principal directions are called **principal strains**.
- The greatest principal strain is called **principal strain one** ( $\epsilon_1$ ).

### Observations

- Principal strains are the maximum and the minimum normal strain at a point.
- A circle in undeformed state will become an ellipse during deformation with major axis as principal axis 1 and minor axis as principal axis 2.

### Visualizing Procedure

- Step 1* Visualize or draw a square with a circle drawn inside it.
- Step 2* Visualize or draw the deformed shape of the square due to *just* normal strains.
- Step 3* Visualize or draw the deformed shape of the rectangle due to the shear strain.
- Step 4* Using the eight  $45^\circ$  sectors shown report the orientation of principal direction 1. Also report principal direction 2 as two sectors counter-clockwise from the sector reported for principal direction 1.

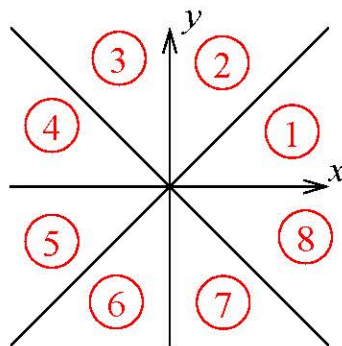

**C9.2** The state of strain at a point in plane strain is as given in each problem. Estimate the orientation of the principal directions and report your results using sectors shown.

$$\varepsilon_{xx} = -400 \mu \quad \varepsilon_{yy} = 600 \mu \quad \gamma_{xy} = -500 \mu$$

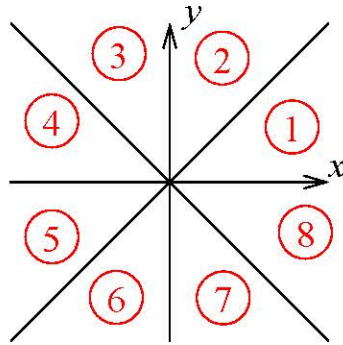

## Class Problem 9.1

Estimate the orientation of the principal directions and report your results using sectors shown.

$$\varepsilon_{xx} = 400 \mu \quad \varepsilon_{yy} = -600 \mu \quad \gamma_{xy} = -500 \mu$$

$$\varepsilon_{xx} = 400 \mu \quad \varepsilon_{yy} = -600 \mu \quad \gamma_{xy} = 500 \mu$$

## Method of Equations

Calculations for  $\varepsilon_{xx}$  acting alone.

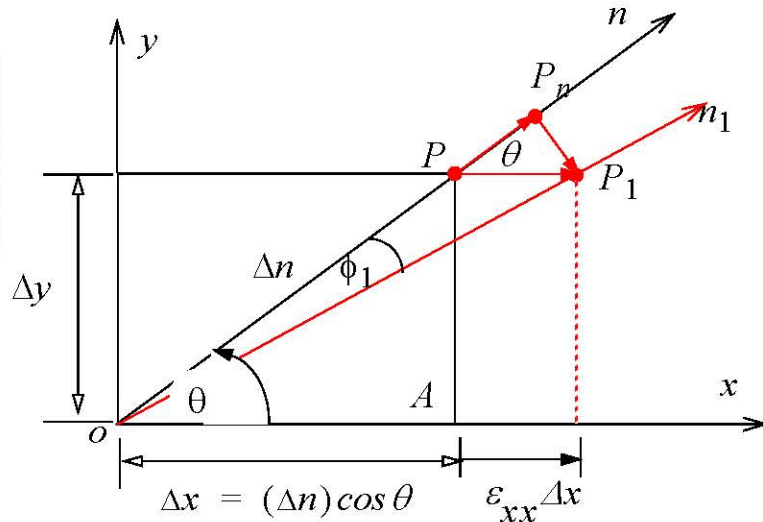
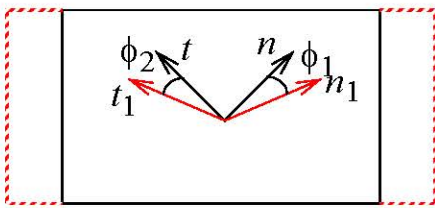

$$\varepsilon_{nn}^{(1)} = \varepsilon_{xx} \cos^2 \theta \quad \varepsilon_{tt}^{(1)} = \varepsilon_{xx} \cos^2(\theta + 90) = \varepsilon_{xx} \sin^2 \theta$$

$$\phi_1 = \varepsilon_{xx} \sin \theta \cos \theta$$

$$\phi_2 = |\varepsilon_{xx} \sin(\theta + 90) \cos(\theta + 90)| = \varepsilon_{xx} \sin \theta \cos \theta$$

$$\gamma_{nt}^{(1)} = -(\phi_1 + \phi_2) = -2\varepsilon_{xx} \sin \theta \cos \theta$$

Calculations for  $\varepsilon_{yy}$  acting alone

$$\varepsilon_{nn}^{(2)} = \varepsilon_{yy} \sin^2 \theta \quad \varepsilon_{tt}^{(2)} = \varepsilon_{yy} \sin^2(\theta + 90) = \varepsilon_{yy} \cos^2 \theta$$

$$\gamma_{nt}^{(2)} = (\phi_1 + \phi_2) = 2\varepsilon_{yy} \sin \theta \cos \theta$$

Calculations for  $\gamma_{xy}$  acting along

$$\varepsilon_{nn}^{(3)} = \gamma_{xy} \sin \theta \cos \theta \quad \varepsilon_{tt}^{(3)} = -\gamma_{xy} \sin \theta \cos \theta$$

$$\gamma_{nt}^{(3)} = (\phi_1 - \phi_2) = \gamma_{xy} (\cos^2 \theta - \sin^2 \theta)$$

**Total Strains:**  $\varepsilon_{nn} = \varepsilon_{nn}^{(1)} + \varepsilon_{nn}^{(2)} + \varepsilon_{nn}^{(3)}$

### Strain Transformation Equations

$$\varepsilon_{nn} = \varepsilon_{xx} \cos^2 \theta + \varepsilon_{yy} \sin^2 \theta + \gamma_{xy} \sin \theta \cos \theta$$

$$\varepsilon_{tt} = \varepsilon_{xx} \sin^2 \theta + \varepsilon_{yy} \cos^2 \theta - \gamma_{xy} \sin \theta \cos \theta$$

$$\gamma_{nt} = -2\varepsilon_{xx} \sin \theta \cos \theta + 2\varepsilon_{yy} \sin \theta \cos \theta + \gamma_{xy} (\cos^2 \theta - \sin^2 \theta)$$

### Stress Transformation equations

$$\sigma_{nn} = \sigma_{xx} \cos^2 \theta + \sigma_{yy} \sin^2 \theta + 2\tau_{xy} \sin \theta \cos \theta$$

$$\sigma_{tt} = \sigma_{xx} \sin^2 \theta + \sigma_{yy} \cos^2 \theta - 2\tau_{xy} \cos \theta \sin \theta$$

$$\tau_{nt} = -\sigma_{xx} \cos \theta \sin \theta + \sigma_{yy} \sin \theta \cos \theta + \tau_{xy} (\cos^2 \theta - \sin^2 \theta)$$

- The coefficient of the shear strain term is half the coefficient of the shear stress term. This difference is due to the fact that we are using engineering strain instead of tensor strain.

## Principal Strains

$$\varepsilon_{1,2} = \frac{(\varepsilon_{xx} + \varepsilon_{yy})}{2} \pm \sqrt{\left(\frac{\varepsilon_{xx} - \varepsilon_{yy}}{2}\right)^2 + \left(\frac{\gamma_{xy}}{2}\right)^2}$$

$$\varepsilon_{nn} + \varepsilon_{tt} = \varepsilon_{xx} + \varepsilon_{yy} = \varepsilon_1 + \varepsilon_2$$

- The angle of principal axis one from the x-axis is only reported in describing the principal coordinate system in two dimensional problems.

$$\tan 2\theta_p = \frac{\gamma_{xy}}{(\varepsilon_{xx} - \varepsilon_{yy})}$$

$$\varepsilon_3 = \begin{cases} 0 & \text{Plane Strain} \\ -\left(\frac{\nu}{1-\nu}\right)(\varepsilon_{xx} + \varepsilon_{yy}) = -\left(\frac{\nu}{1-\nu}\right)(\varepsilon_1 + \varepsilon_2) & \text{Plane Stress} \end{cases}$$

## Maximum Shear strain

- The maximum shear strain in coordinate systems that can be obtained by rotating about the z-axis is called the **in-plane maximum shear strain**.

$$\left|\frac{\gamma_p}{2}\right| = \left|\frac{\varepsilon_1 - \varepsilon_2}{2}\right|$$

- The **maximum shear strain** at a point is the absolute maximum shear strain that can be obtained in a coordinate system by considering rotation about all three axes.

$$\frac{\gamma_{max}}{2} = \max\left(\left|\frac{\varepsilon_1 - \varepsilon_2}{2}\right|, \left|\frac{\varepsilon_2 - \varepsilon_3}{2}\right|, \left|\frac{\varepsilon_3 - \varepsilon_1}{2}\right|\right)$$

- Maximum shear strain in plane stress and plane strain will be different.



**C9.3** At a point in plane strain, the strain components in the x-y coordinate system are as given in each problem. Using Method of Equations determine

- the principal strains and principal angle one.
- the maximum shear strain.
- the strain components in the n-t coordinate system shown in each problem.

$$\varepsilon_{xx} = -600 \mu$$

$$\varepsilon_{yy} = -800 \mu$$

$$\gamma_{xy} = 500 \mu$$

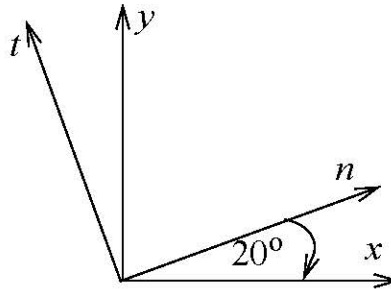

## Mohr's Circle for Strains

$$\varepsilon_{nn} = \frac{(\varepsilon_{xx} + \varepsilon_{yy})}{2} + \frac{(\varepsilon_{xx} - \varepsilon_{yy})}{2} \cos 2\theta + \left(\frac{\gamma_{xy}}{2}\right) \sin 2\theta$$

$$\left(\frac{\gamma_{nt}}{2}\right) = -\frac{(\varepsilon_{xx} - \varepsilon_{yy})}{2} \sin 2\theta + \left(\frac{\gamma_{xy}}{2}\right) \cos 2\theta$$

$$\left(\varepsilon_{nn} - \frac{\varepsilon_{xx} + \varepsilon_{yy}}{2}\right)^2 + \left(\frac{\gamma_{nt}}{2}\right)^2 = \left(\frac{\varepsilon_{xx} - \varepsilon_{yy}}{2}\right)^2 + \left(\frac{\gamma_{xy}}{2}\right)^2$$

- Each point on the Mohr's circle represents a unique direction passing through the point at which the strains are specified.
- The coordinates of each point on the circle are the strains  $(\varepsilon_{nn}, \gamma_{nt}/2)$ .
- On Mohr's circle, lines are separated by twice the actual angle between the lines.

### Construction of the Mohr's Circle for strain.

Step 1. Draw a square with deformed shape due to shear strain  $\gamma_{xy}$ . Label the *intersection* of the vertical plane and x-axis as V and the *intersection* of the horizontal plane and y-axis as H.

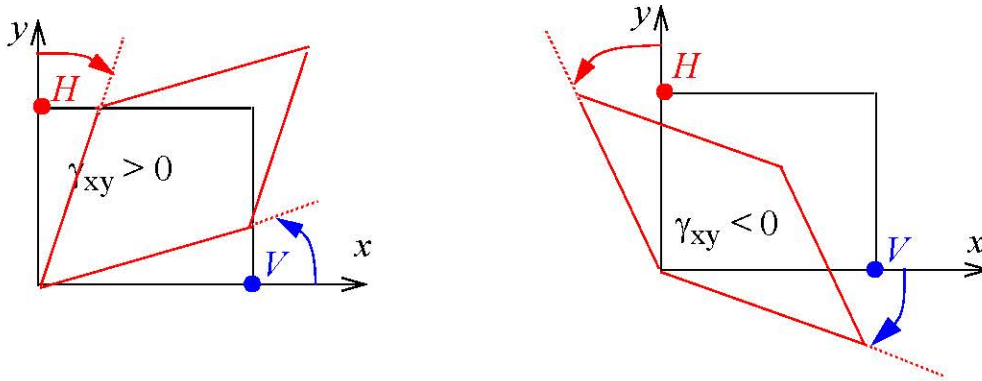

Step 2. Write the coordinates of point V and H as:

$$V(\epsilon_{xx}, \gamma_{xy}/2) \quad \text{and} \quad H(\epsilon_{yy}, \gamma_{xy}/2) \quad \text{for} \quad \gamma_{xy} > 0$$

Step 3. Draw the horizontal axis to represent the normal strain, with extension to the right and contractions to the left. Draw the vertical axis to represent **half the shear strain**, with clockwise rotation of a line in the upper plane and counter-clockwise rotation of a line of rotation lower plane.

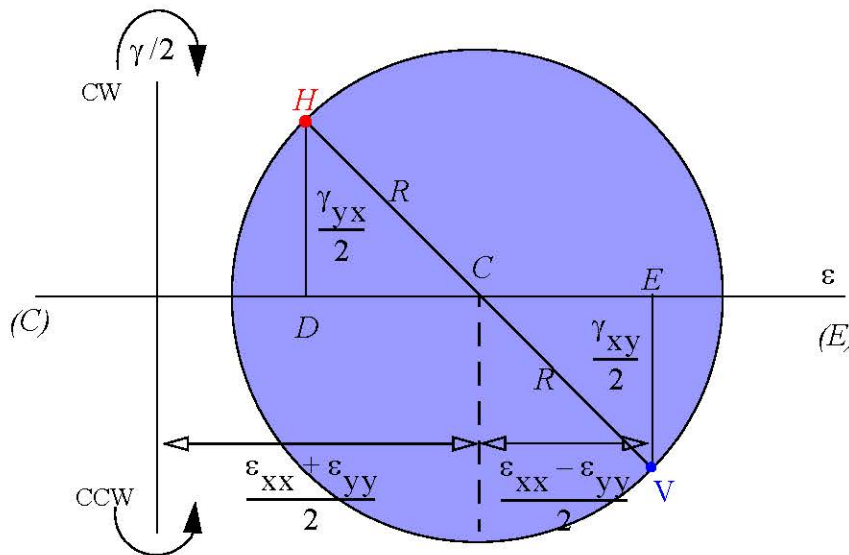

*Step 4.* Locate points V and H and join the points by drawing a line. Label the point at which the line VH intersects the horizontal axis as C.

*Step 5.* With C as center and CV or CH as radius draw the Mohr's circle.

### Principal Strains & Maximum In-Plane Shear Strain

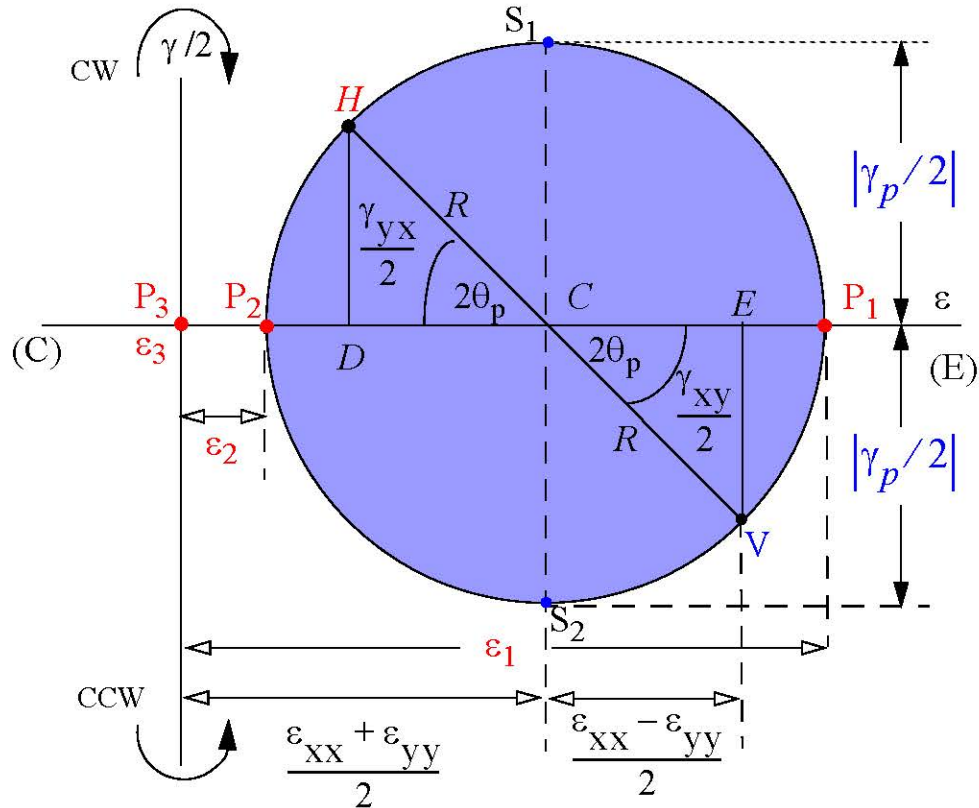

- The principal angle one  $\theta_1$  is the angle between line CV and CP<sub>1</sub>. Depending upon the Mohr circle  $\theta_1$  may be equal to  $\theta_p$  or equal to  $(\theta_p \pm 90^\circ)$ .

### Maximum Shear Strain

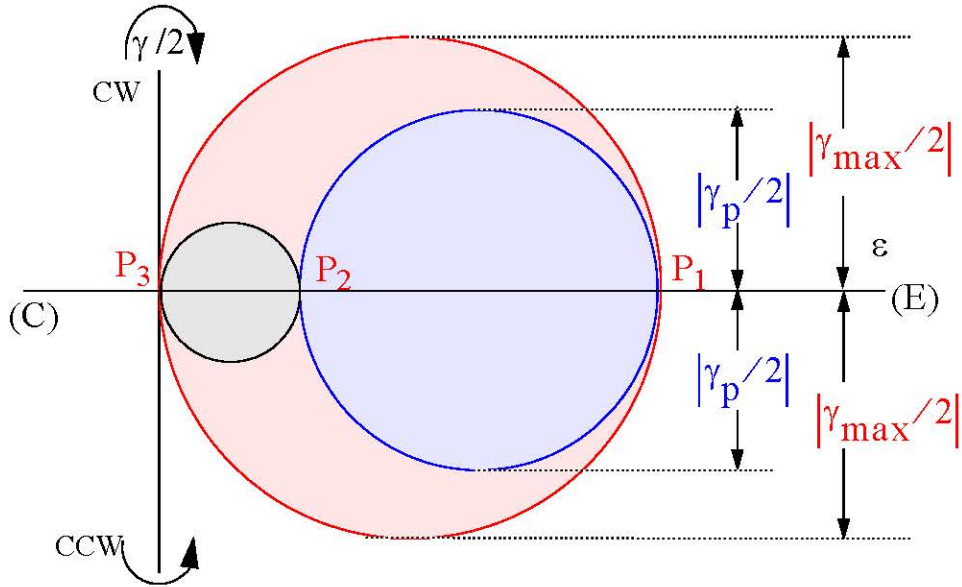

### Strains in a Specified Coordinate System

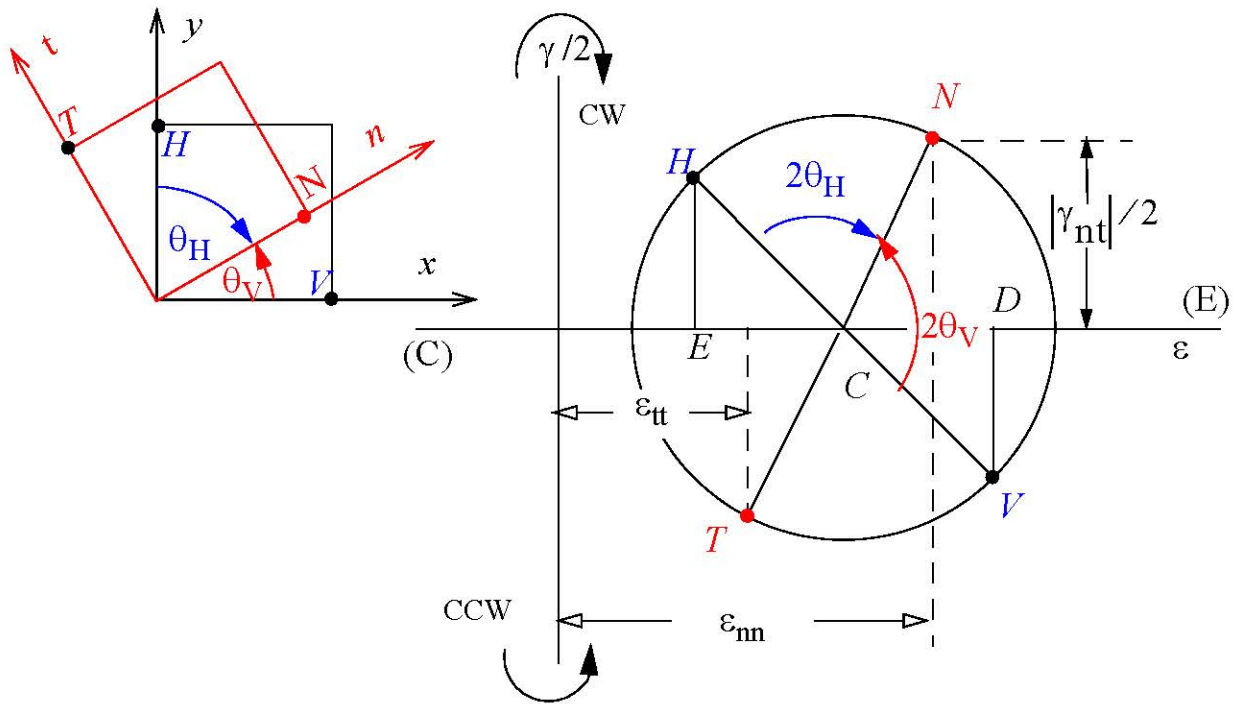

### Sign of shear strain

The coordinates of point N and T are as shown below:

$$N(\varepsilon_{nn}, \gamma_{nt}/2) \quad \text{and} \quad T(\varepsilon_{tt}, \gamma_{nt}/2)$$

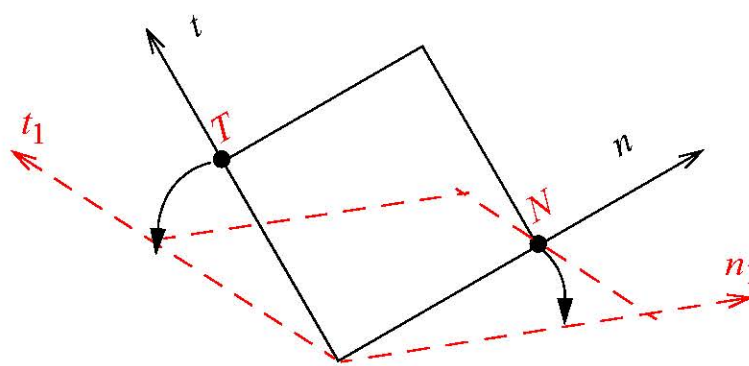

- Increase in angle results in negative shear strain and decrease in angle results in positive shear strains.

**C9.4** At a point in plane strain, the strain components in the  $x$ - $y$  coordinate system are as given in each problem. Using Mohr's circle determine

- the principal strains and principal angle one.
- the maximum shear strain.
- the strain components in the  $n$ - $t$  coordinate system shown in each problem.

$$\varepsilon_{xx} = -600 \mu$$

$$\varepsilon_{yy} = -800 \mu$$

$$\gamma_{xy} = 500 \mu$$

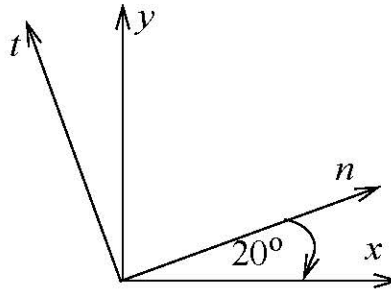

## Class Problem 9.2

The Mohr's circle corresponding to a given state of strain are shown. Identify the circle you would use to find the strains in the  $n, t$  coordinate system in each question.

1.

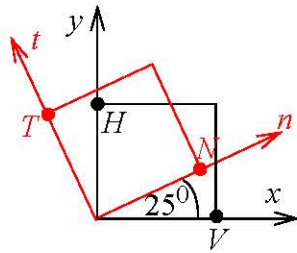

2.

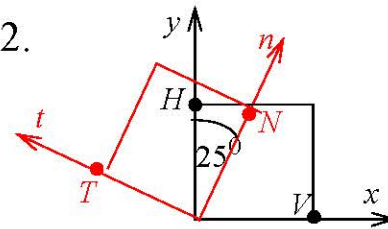

Circle A

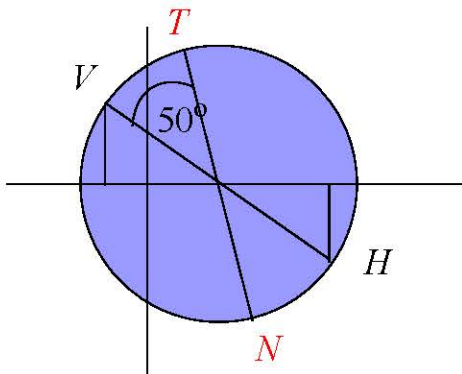

Circle B

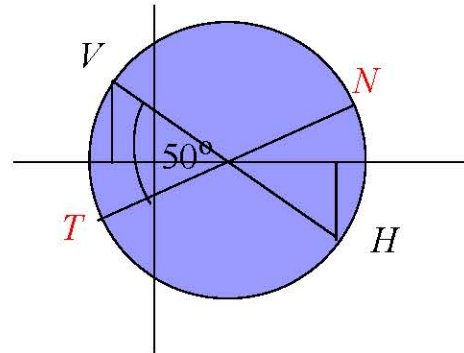

Circle C

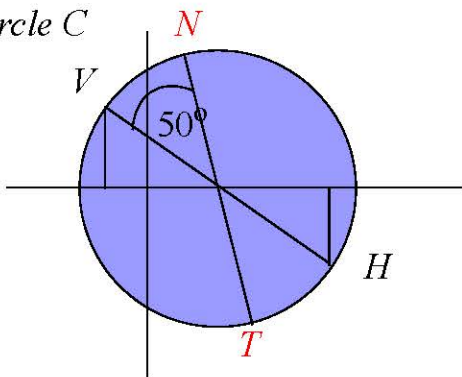

Circle D

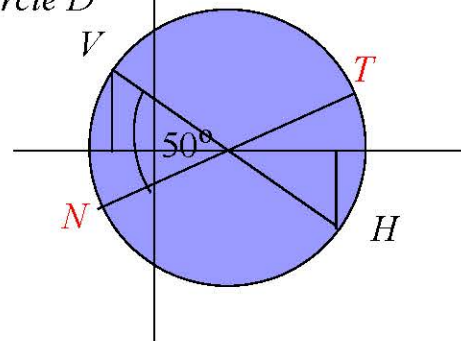



## Generalized Hooke's Law in Principal Coordinates

- Generalized Hooke's Law is valid for any orthogonal coordinate system.
- Principal coordinates for stresses and strains are orthogonal.
- For isotropic materials, the principal directions for strains are the same as principal directions for stresses.

$$\varepsilon_1 = [\sigma_1 - \nu(\sigma_2 + \sigma_3)]/E$$

$$\varepsilon_2 = [\sigma_2 - \nu(\sigma_3 + \sigma_1)]/E$$

$$\varepsilon_3 = [\sigma_3 - \nu(\sigma_1 + \sigma_2)]/E$$

## Strain Gages

- Strain gages measure only normal strains directly.
- Strain gages are bonded to a free surface, i.e., the strains are in a state of plane stress and not plane strain.
- Strain gages measure average strain at a point.

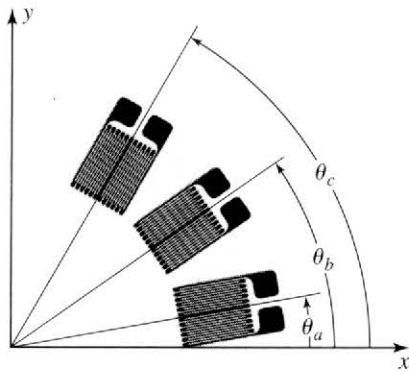

$$\varepsilon_a = \varepsilon_{xx} \cos^2 \theta_a + \varepsilon_{yy} \sin^2 \theta_a + \gamma_{xy} \sin \theta_a \cos \theta_a$$

$$\varepsilon_b = \varepsilon_{xx} \cos^2 \theta_b + \varepsilon_{yy} \sin^2 \theta_b + \gamma_{xy} \sin \theta_b \cos \theta_b$$

$$\varepsilon_c = \varepsilon_{xx} \cos^2 \theta_c + \varepsilon_{yy} \sin^2 \theta_c + \gamma_{xy} \sin \theta_c \cos \theta_c$$

### Strain Rosette

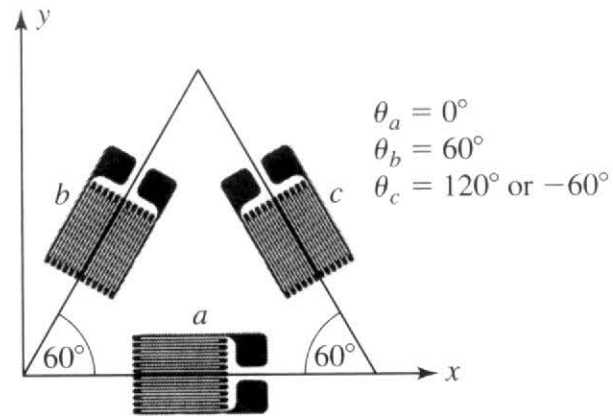
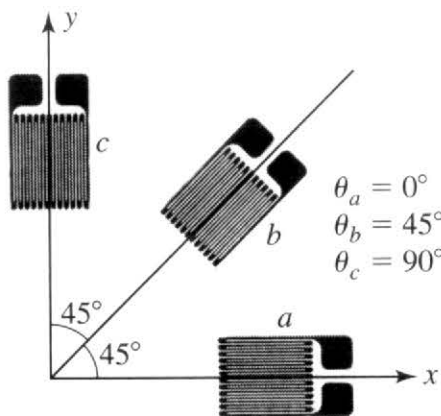

- The change in strain gage orientation by  $\pm 180^\circ$  makes no difference to the strain values.

**C9.5** At a point on a free surface of aluminum ( $E = 10,000$  ksi and  $G = 4,000$  ksi) the strains recorded by the three strain gages shown in Fig. C9.5 are as given. Determine the stresses  $\sigma_1$ ,  $\sigma_2$ ,  $\theta_1$  and  $\tau_{\max}$ .

$$\varepsilon_a = -600 \mu \text{ in/in}$$

$$\varepsilon_b = 500 \mu \text{ in/in}$$

$$\varepsilon_c = 400 \mu \text{ in/in}$$

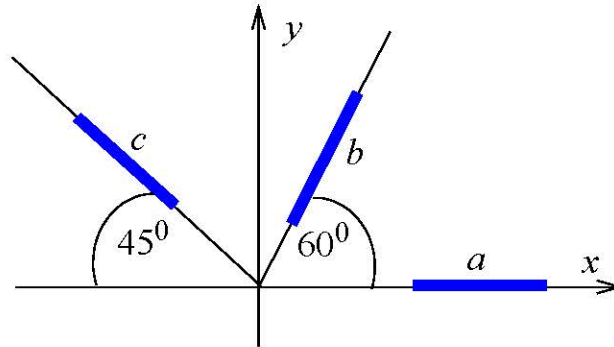
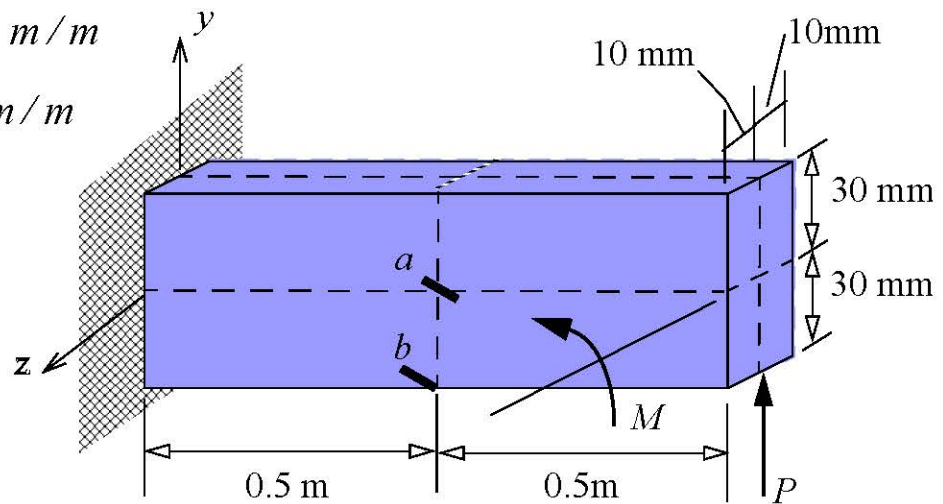

**Fig. C9.5**

**C9.6** An aluminum ( $E = 70 \text{ GPa}$ , and  $\nu = 0.25$ ) beam is loaded by a force  $P$  and moment  $M$  at the free end as shown in Figure 9.6. Two strain gages at  $30^\circ$  to the longitudinal axis recorded the strains given. Determine the applied force  $P$  and applied moment  $M$ .

$$\varepsilon_a = -386 \mu m/m$$

$$\varepsilon_b = 4092 \mu m/m$$



**Fig. C9.6**