

# Design and Failure



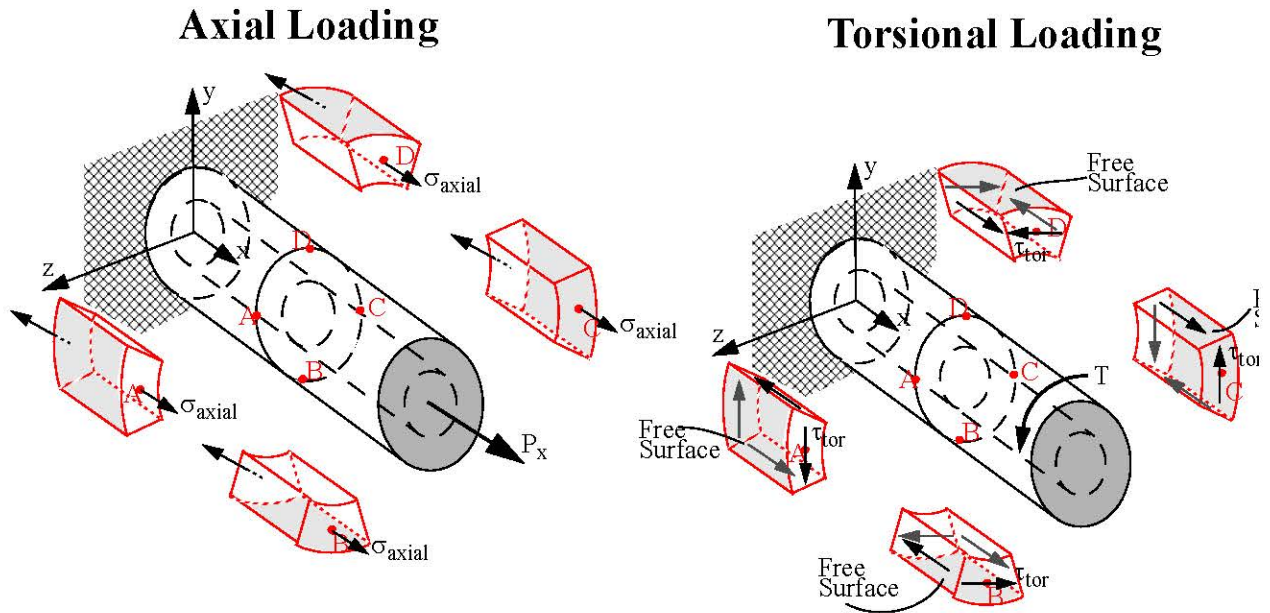
## Learning objectives

- Learn the computation of stresses and strains in structural members subjected to combined axial, torsion, and bending loads.
- Develop the analysis skills for computation of internal forces and moments on individual members that compromise a structure.

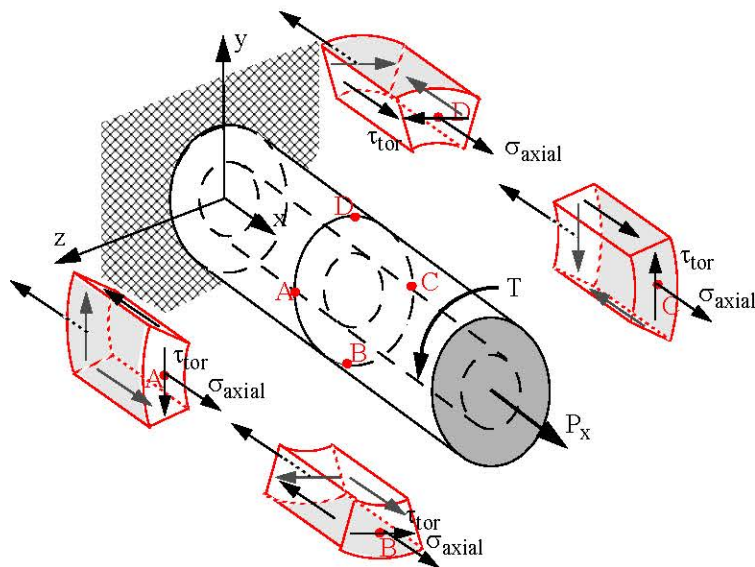
## Combined Loading

	Non-zero Stresses	Non-zero Strains
<b>Axial</b>	$\sigma_{xx} = \frac{N}{A}$	$\epsilon_{xx} = \frac{\sigma_{xx}}{E}$ $\epsilon_{yy} = -\left(\frac{\nu\sigma_{xx}}{E}\right) \quad \epsilon_{zz} = -\left(\frac{\nu\sigma_{xx}}{E}\right)$
<b>Torsion</b>	$\tau_{x\theta} = \frac{T\rho}{J}$	$\gamma_{x\theta} = \frac{\tau_{x\theta}}{G}$
<b>Symmetric Bending about z-axis</b>	$\sigma_{xx} = -\left(\frac{M_z y}{I_{zz}}\right)$ $\tau_{xs} = -\left(\frac{V_y Q_z}{I_{zz} t}\right)$	$\epsilon_{xx} = \frac{\sigma_{xx}}{E}$ $\epsilon_{yy} = -\left(\frac{\nu\sigma_{xx}}{E}\right) \quad \epsilon_{zz} = -\left(\frac{\nu\sigma_{xx}}{E}\right)$ $\gamma_{xs} = \frac{\tau_{xs}}{G}$
<b>Symmetric Bending about y-axis</b>	$\sigma_{xx} = -\left(\frac{M_y z}{I_{yy}}\right)$ $\tau_{xs} = -\left(\frac{V_z Q_y}{I_{yy} t}\right)$	$\epsilon_{xx} = \frac{\sigma_{xx}}{E}$ $\epsilon_{yy} = -\left(\frac{\nu\sigma_{xx}}{E}\right) \quad \epsilon_{zz} = -\left(\frac{\nu\sigma_{xx}}{E}\right)$ $\gamma_{xs} = \frac{\tau_{xs}}{G}$

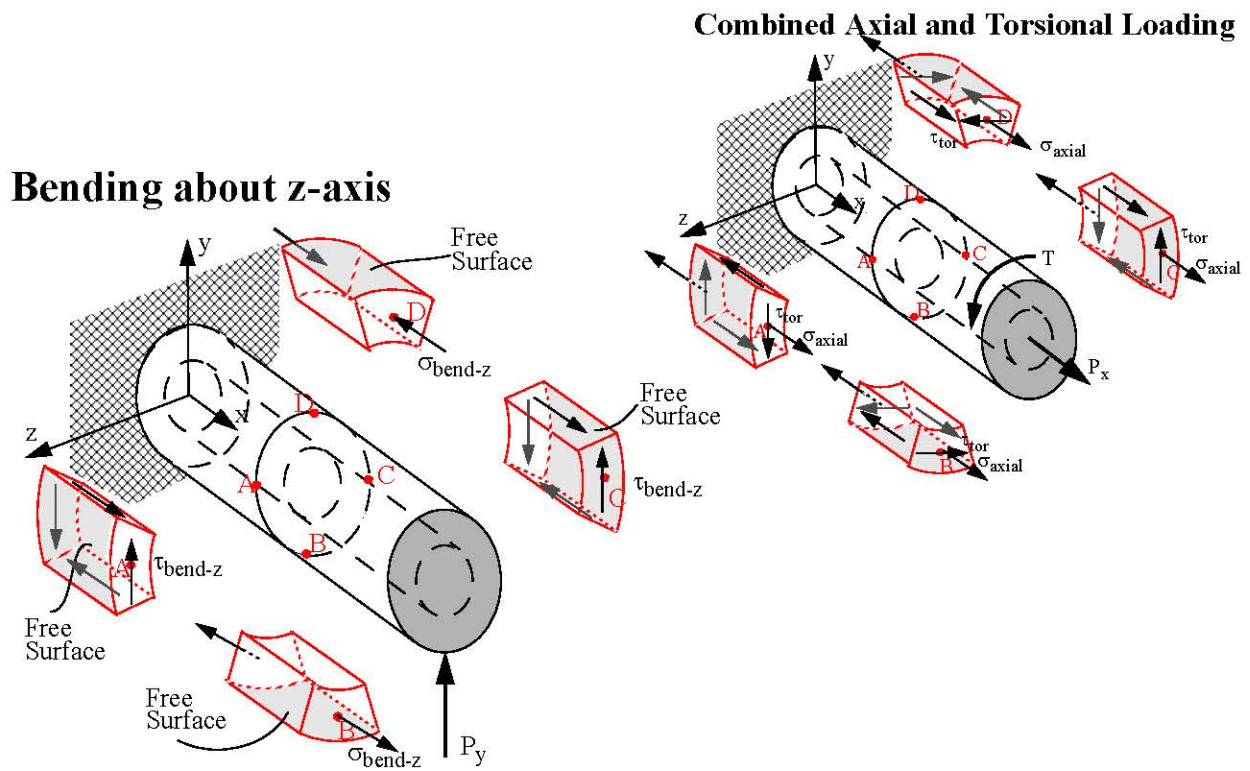
## Combined Axial and Torsional Loading



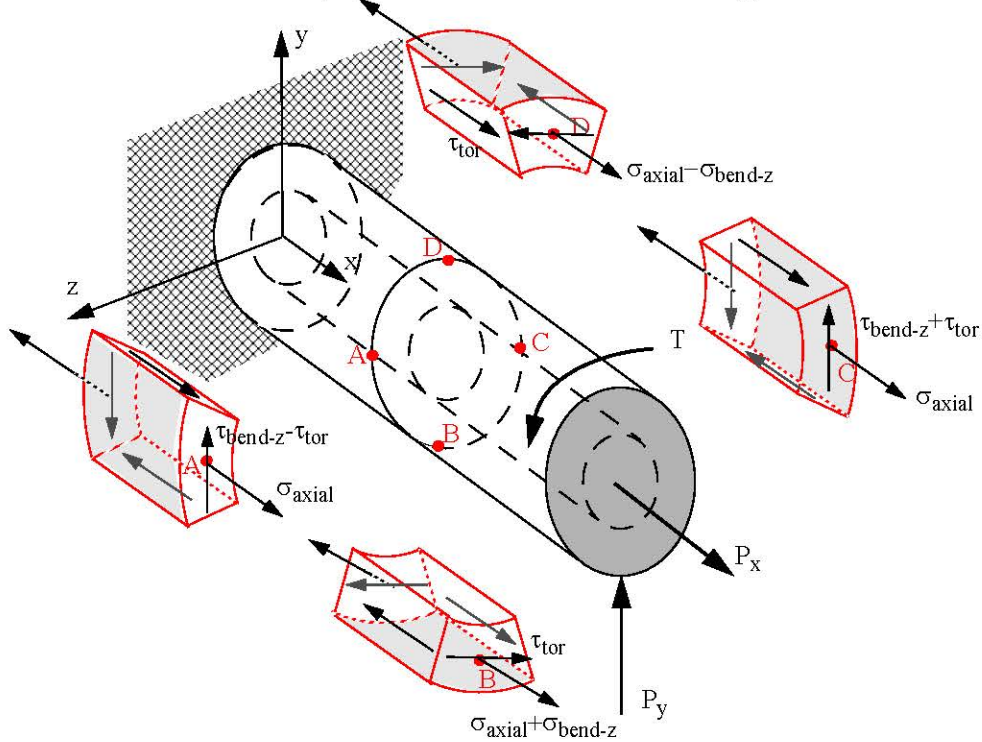
## Combined Axial and Torsional Loading



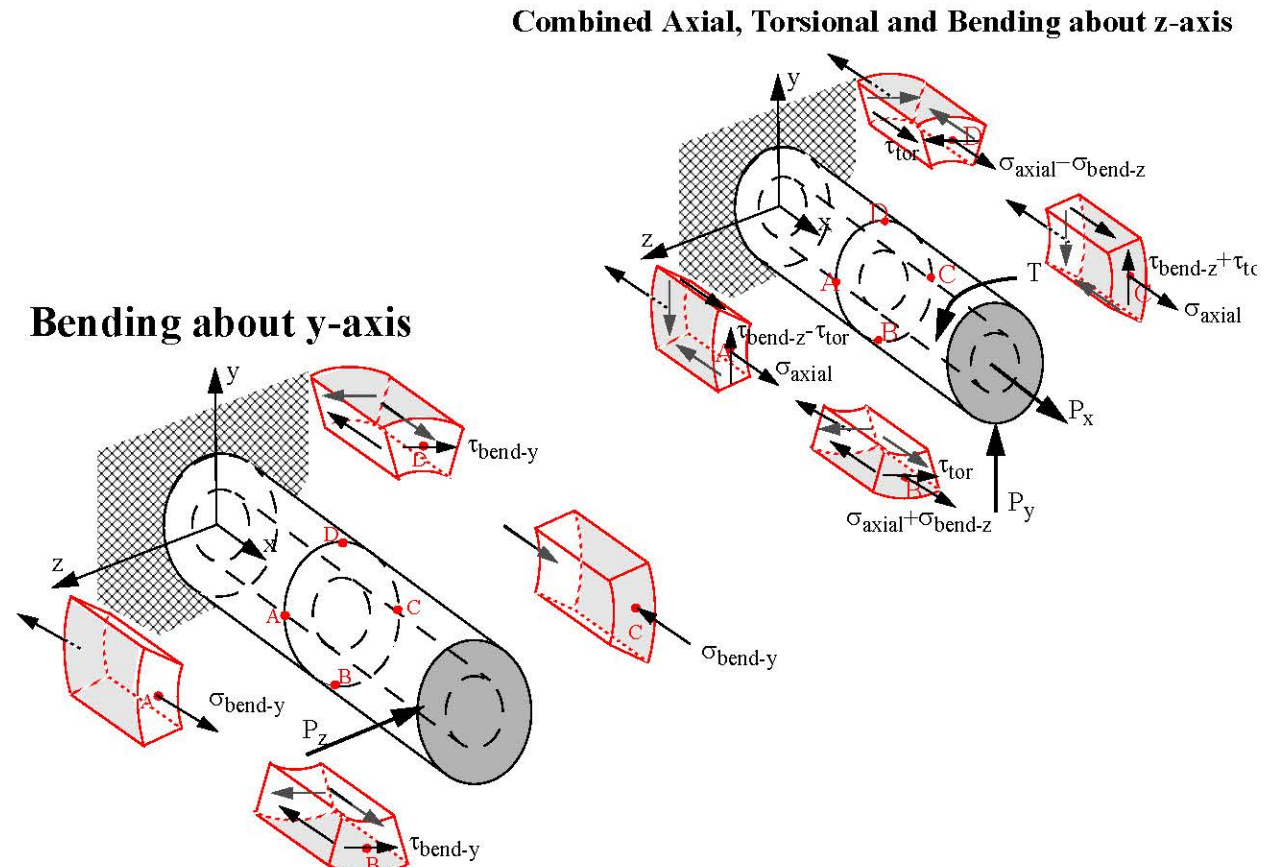
## Combined Axial, Torsional and Bending about z-axis



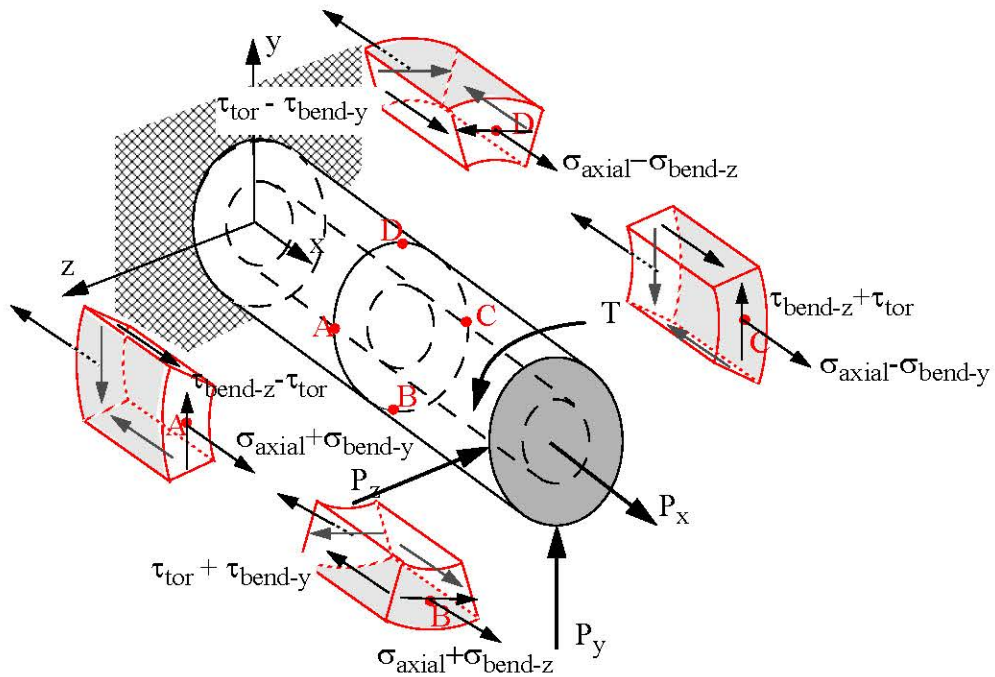
## Combined Axial, Torsional and Bending about z-axis



## Combined Axial, Torsional and Bending about y and z-axis



## Combined Axial, Torsional and Bending about y and z-axis



Printed from: <http://madhuvable.org/free-downloads>

## Important Points

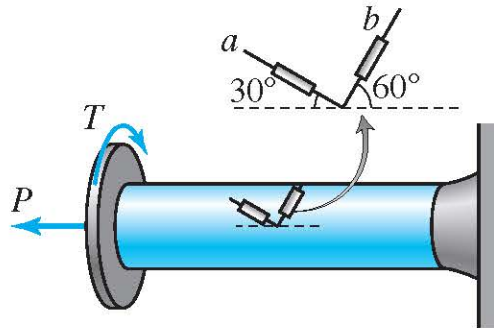
- The complexity of finding the state of stress under combined loading can be simplified by first determining the state of stress due to individual loading.
- Superposition of stresses implies that a stress component at a **specific point** resulting from one loading can be added or subtracted to a **similar stress component** from another loading. Stress components at different points cannot be added or subtracted nor can stress components which act on different planes or in different directions be added or subtracted.
- The stress formulas give both the correct magnitude correct direction for each stress component if the **internal forces and moments** are **drawn** on the free body diagrams **as per the sign conventions**.
- In a structure, the structural members will have different orientations. In order to use subscripts to determine the direction (sign) of stress components, a local x, y, z coordinate system can be established for a structural member such that the x direction is normal to cross-section, i.e., the x-direction is along the axis of the structural member.
- Stresses  $\sigma_{yy}$  and  $\sigma_{zz}$  are zero for the four load cases. Additional stress components can be deduced to be zero by identifying free surfaces.
- The state of stress in combined loading should be shown on a stress cube before processing the stresses for purpose of stress or strain transformation.
- The strains at a point can be obtained from the superposed stress values using the Generalized Hooke's Law. As the normal stresses  $\sigma_{yy}$  and  $\sigma_{zz}$  are always zero in our structural members, the non-zero strains  $\epsilon_{yy}$  and  $\epsilon_{zz}$  are due to the Poisson's effect,

i.e., 
$$\epsilon_{yy} = \epsilon_{zz} = -\nu\epsilon_{xx} \quad .$$

## General Procedure for Combined Loading

- Identify the relevant equations for the problem and use the equations as a check list for the quantities that must be calculated.
- Calculate the relevant geometric properties ( $A$ ,  $I_{yy}$ ,  $I_{zz}$ ,  $J$ ) of the cross-section containing the points where stresses have to be found.
- At points where shear stress due to bending is to be found, draw a line perpendicular to the center-line through the point and calculate the first moments of the area ( $Q_y$ ,  $Q_z$ ) between free surface and the drawn line. Record the  $s$ -direction from the free surface towards the point where stress is being calculated.
- Make an imaginary cut through the cross-section and draw the free body diagram. On the free body diagram draw the internal forces and moments as per our sign conventions if subscripts are to be used in determining the direction of stress components. Using equilibrium equations to calculate the internal forces and moments.
- Using the equations identified, calculate the individual stress components due to each loading. Draw the torsional shear stress  $\tau_{x\theta}$  and bending shear stress  $\tau_{xs}$  on a stress cube using subscripts or by inspection. By examining the shear stresses in  $x, y, z$  coordinate system obtain  $\tau_{xy}$  and  $\tau_{xz}$  with proper sign.
- Superpose the stress components to obtain the total stress components at a point.
- Show the calculated stresses on a stress cube.
- Interpret the stresses shown on the stress cube in the  $x, y, z$  coordinate system before processing these stresses for the purpose of stress or strain transformation.

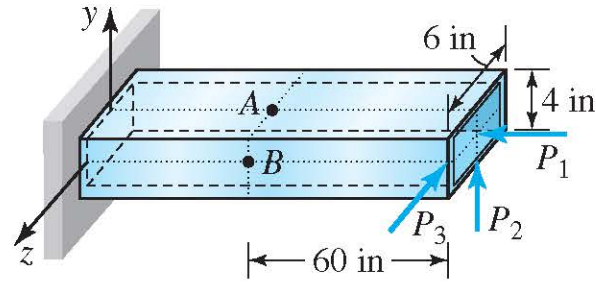
**C10.1** A solid shaft of 2 inch diameter is loaded as shown in Fig. C10.1. The shaft material has a Modulus of Elasticity of  $E = 30,000$  ksi and a Poisson's ratio of  $\nu = 0.3$ . The strain gages mounted on the surface of the shaft recorded the following strain values:  $\epsilon_a = 2078 \mu$   $\epsilon_b = -1410 \mu$ . Determine the axial force  $P$  and the torque  $T$ .



**Fig. C10.1**



**C10.2** A rectangular hollow member is constructed from a  $1/2$  inch thick sheet metal and loaded as shown Fig. C10.2. Determine the normal and shear stresses at points A and B and show it on the stress cubes for  $P_1 = 72$  kips,  $P_2 = 0$ , and  $P_3 = 6$  kips.



**Fig. C10.2**

**C10.3** A load is applied to bent pipes as shown. By inspection determine and show the total stresses at points  $A$  and  $B$  on stress cubes using the following notation for the *magnitude* of stress components:

$\sigma_{\text{axial}}$  —axial normal stress;

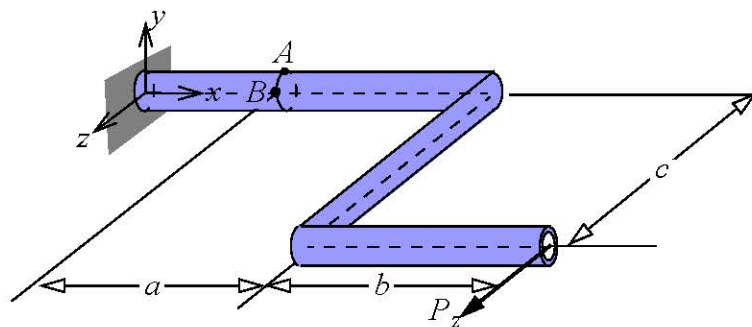
$\tau_{\text{tor}}$ —torsional shear stress;

$\sigma_{\text{bend-y}}$  —normal stress due to bending about  $y$ -axis;

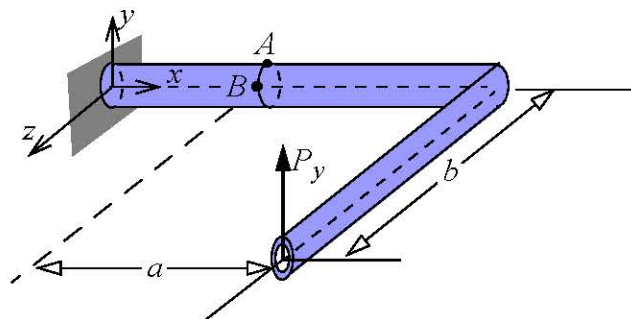
$\tau_{\text{bend-y}}$  —shear stress due to bending about  $y$ -axis;

$\sigma_{\text{bend-z}}$  —normal stress due to bending about  $z$ -axis;

$\tau_{\text{bend-z}}$  —shear stress due to bending about  $z$ -axis.

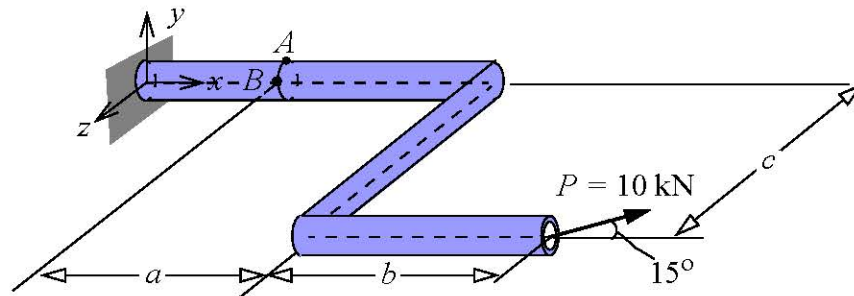


## Class Problem 10.1



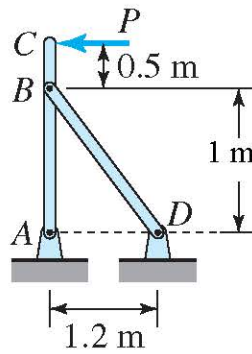
**C10.4** A pipe with an outside diameter of 40 mm and wall thickness of 10 mm is loaded as shown in Fig. C10.5. Determine the normal and shear stresses at point  $A$  and  $B$  in the  $x$ ,  $y$ , and  $z$  coordinate system and show it on a stress cube. Points  $A$  and  $B$  are on the surface of the pipe. Use  $a = 0.25$  m,  $b = 0.4$  m, and  $c = 0.1$  m

**C10.5** Determine the maximum normal stress and maximum shear stress at point  $B$  on the pipe shown in Fig. C10.5.

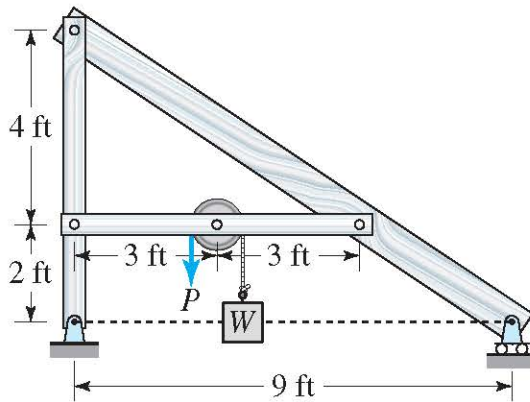


**Fig. C10.5**

**C10.6** The bars in the pin connected structure shown are circular bars of diameters that are available in increments of 5 mm. The allowable shear stress in the bars is 90 MPa. Determine the diameters of the bars for designing the lightest structure to support a force of  $P = 40$  kN.



**C10.7** A hoist is to be designed for lifting a maximum weight of  $W = 300$  lbs. The hoist will be installed at a certain height above ground and will be constructed using lumber and assembled using steel bolts. The lumber rectangular cross-section dimensions are listed in table below. The bolt joints will be modeled as pins in single shear. Same size bolts will be used in all joints. The allowable normal stress in the wood is 1.2 ksi and the allowable shear stress in bolts is 6 ksi. Design the lightest hoist by choosing the lumber from the given table and bolt size to the nearest 1/8 inch diameter.



Cross-section Dimension
2 in x 4 in
2 in x 6 in
2 in x 8 in
4 in x 4 in
4 in x 6 in
4 in x 8 in
6 in x 6 in
6 in x 8 in
8 in x 8 in