

Stress

- A variable that can be used as a measure of strength of a structural member.

Learning objectives

- Understanding the concept of stress.
- Understanding the two step analysis of relating stresses to external forces and moments.

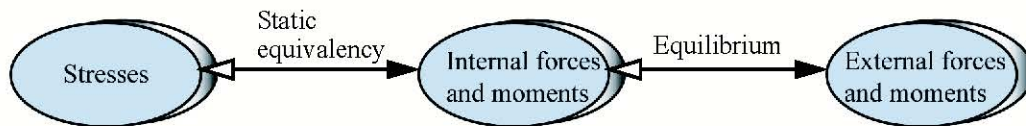

Normal Stress

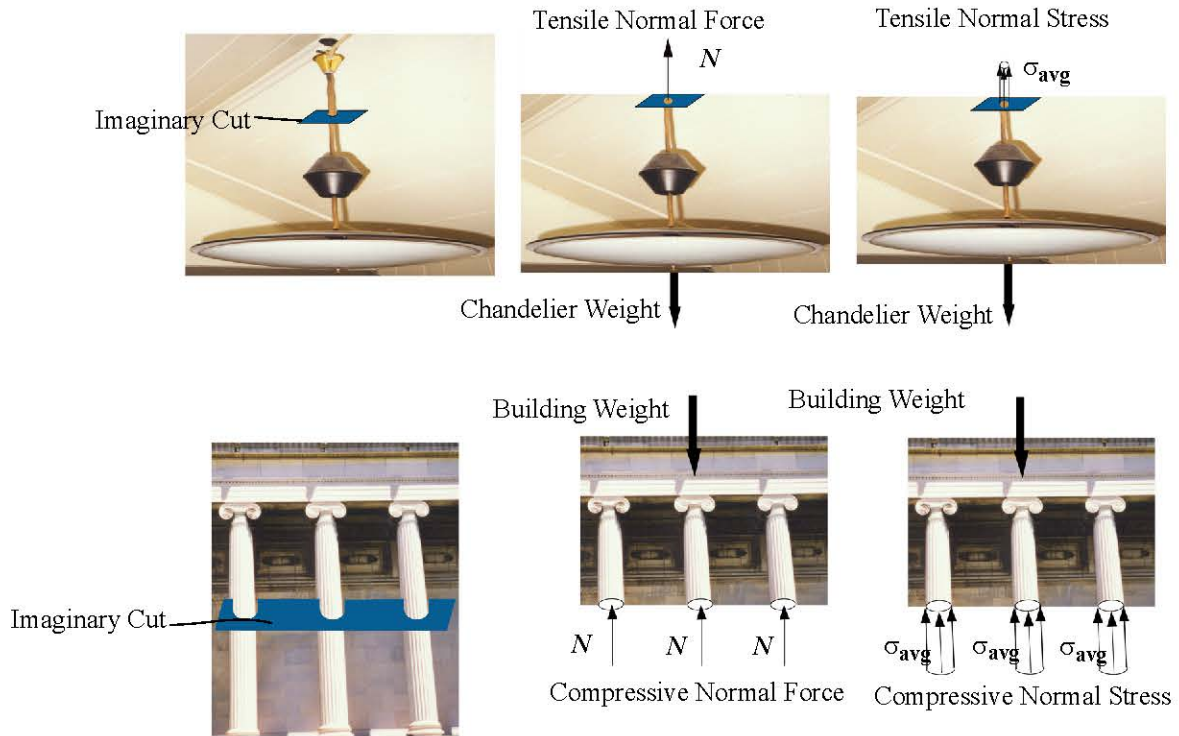

$$\sigma_{av} = N/A$$

- All internal forces (and moments) in the book are in ***bold italics***
- Normal stress that pulls the surface away from the body is called a **ten-**
sile stress.
- Normal stress that pushes the surface into the body is called a **com-**
pressive stress.
- The normal stress acting in the direction of the axis of a slender mem-
ber (rods, cables, bars, columns, etc.) is called the **axial stress**.
- The compressive normal stress that is produced when one surface
presses against other is called the **bearing stress**.

Abbreviation	Units	Basic Units
psi	Pounds per square inch	lb/in. ²
ksi	Kilopounds (kips) per square inch	10 ³ lb/in. ²
Pa	Pascal	N/m ²
kPa	Kilopascal	10 ³ N/m ²
MPa	Megapascal	10 ⁶ N/m ²
GPa	Gigapascal	10 ⁹ N/m ²

C1.1 A 6 kg light shown in Fig. C1.1 is hanging from the ceiling by wires of diameter of 0.75 mm. Determine the tensile stress in the wires AB and BC.

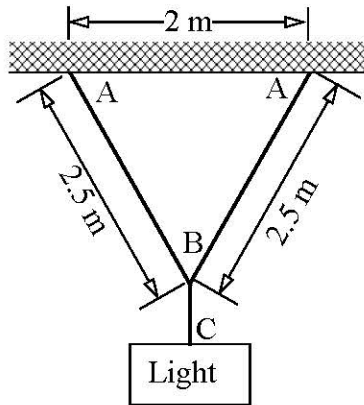
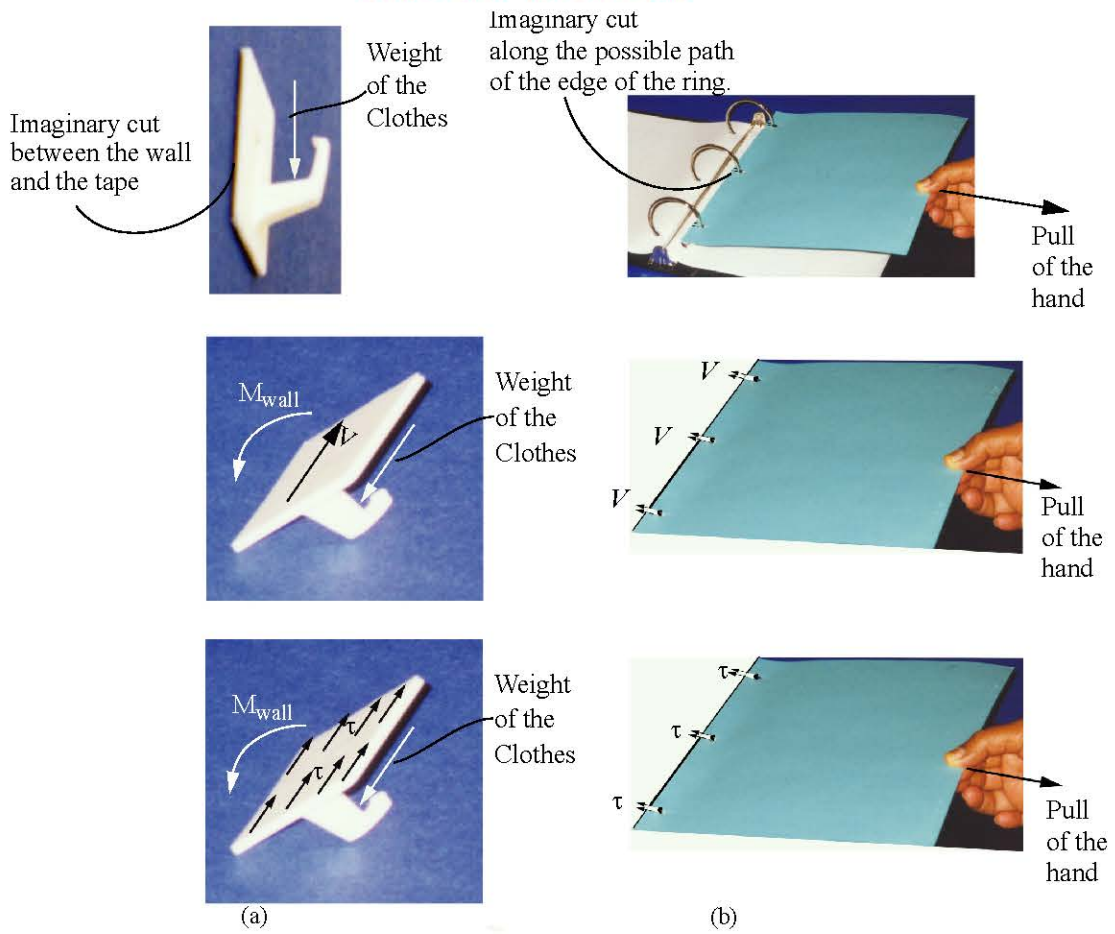

Fig. C1.1

Shear Stress



$$\tau_{av} = V/A$$

Shear stress in pins

- Visualizing the surface on which stress acts is very important.

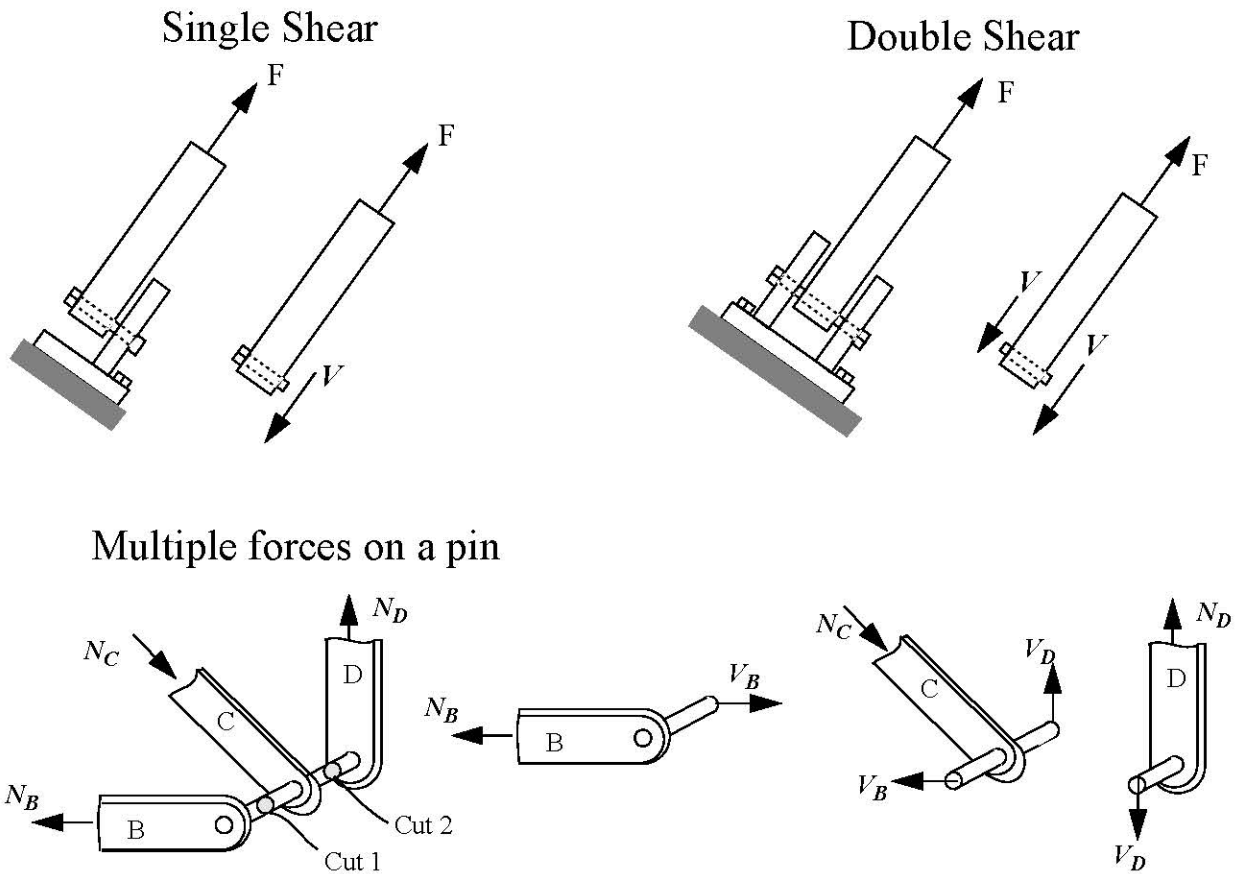

C1.2 The device shown in Fig. C1.2 is used for determining the shear strength of the wood. The dimensions of the wood block are 6 in x 8 in x 1.5 in. If the force required to break the wood block is 12 kips, determine the average shear strength of the wood.

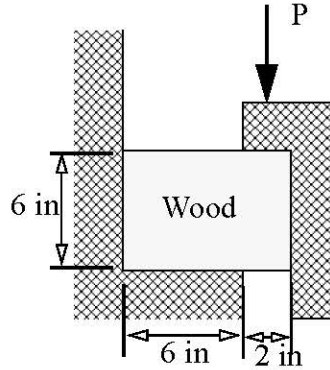

Fig. C1.2

C1.3 Two cast iron pipes are held together by a bolt as shown. The outer diameters of the two pipes are 50 mm and 70 mm and wall thickness of each pipe is 10 mm. The diameter of the bolt is 15 mm. The bolt broke while transmitting a torque of 2 kN-m. On what surface(s) did the bolt break? What was the average shear stress in the bolt on the surface where it broke?

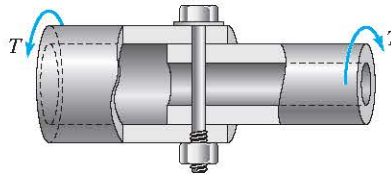

Fig. C1.3

C1.4 Fig. C1.4 shows a truss and the sequence of assembly of members at pin H. All members of the truss have a cross-sectional area of 250 mm^2 and all pins have a diameter of 15 mm. (a) Determine the axial stresses in members HA, HB, HG and HC of the truss shown in Fig. C1.4. (b) Determine the maximum shear stress in pin H.

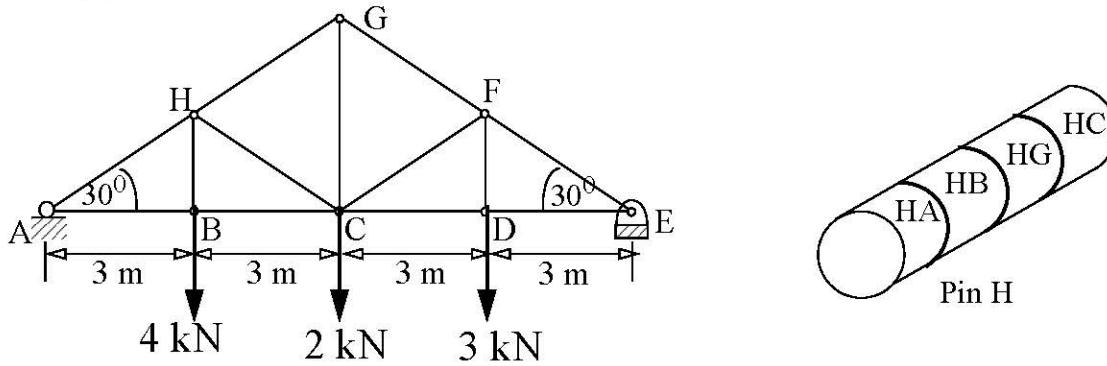
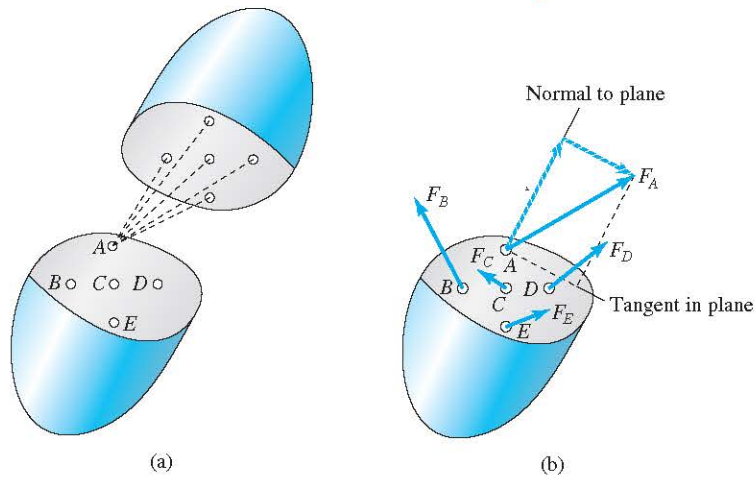
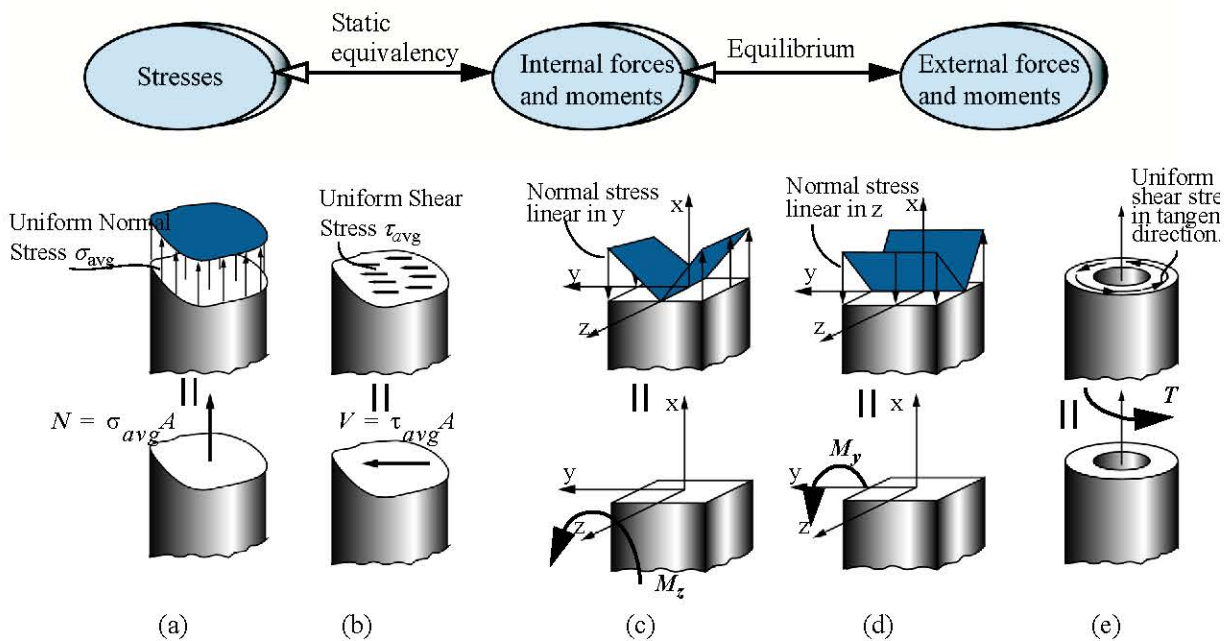

Fig. C1.4

Internally Distributed Force System



- The intensity of internal distributed forces on an imaginary cut surface of a body is called the *stress on a surface*.
- The intensity of internal distributed force that is normal to the surface of an imaginary cut is called the *normal stress* on a surface.
- The intensity of internal distributed force that is parallel to the surface of an imaginary cut surface is called the *shear stress* on the surface.
- Relating stresses to external forces and moments is a two step process.



Printed from: <http://madhuvable.org/free-downloads>

C1.5 An adhesively bonded joint in wood is fabricated as shown in Fig. C1.5. The joint is to support a force $P = 25$ kips, what should be the length L of the bonded region if the adhesive strength in shear is 300 psi.

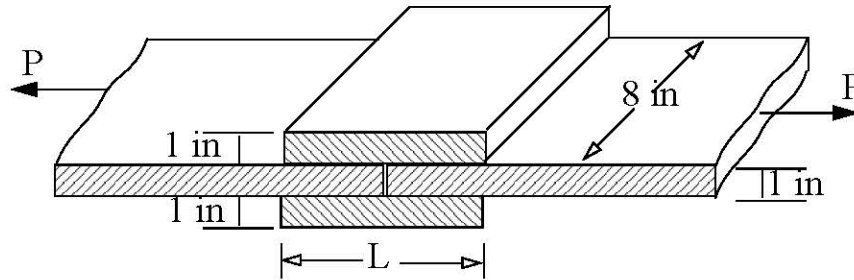
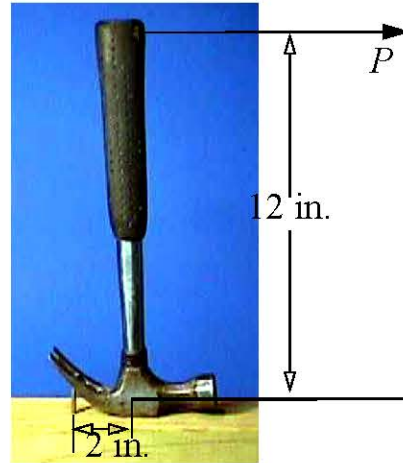

Fig. C1.5

Class Problem 1.1

In problems below, draw the free body diagram (FBD) that can be used for calculation of shear stress. Identify the surface and the direction of shear stress.

1.1a A nail is being pulled out using a claw hammer. Assuming the nail does not bend or break and the hammer does not slip. Show the shear stress on the nail in the FBD.



1.1b Two pipes that were adhesively bonded. Show the shear stress in the adhesive in the FBD.

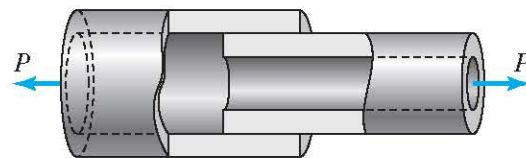

1.1c n -bolts are used to hold the coupling together. Show the shear stress in the bolts in the FBD

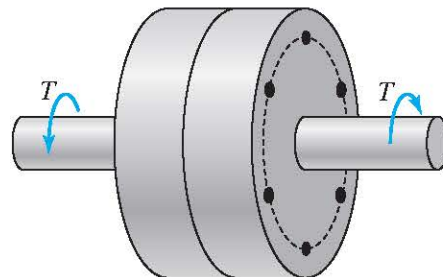

Stress at a Point

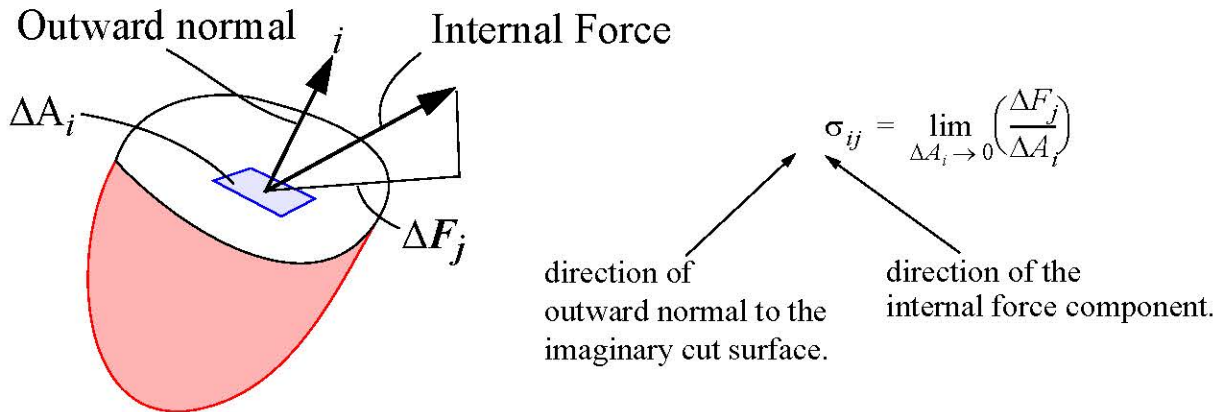

- ΔA_i will be considered positive if the outward normal to the surface is in the positive i direction.
- A stress component is positive if numerator and denominator have the same sign. Thus σ_{ij} is positive if: (1) ΔF_j and ΔA_i are both positive. (2) ΔF_j and ΔA_i are both negative.

- **Stress Matrix in 3-D:**

$$\begin{bmatrix} \sigma_{xx} & \tau_{xy} & \tau_{xz} \\ \tau_{yx} & \sigma_{yy} & \tau_{yz} \\ \tau_{zx} & \tau_{zy} & \sigma_{zz} \end{bmatrix}$$

Table 1.1 Comparison of number of components

Quantity	One Dimension	Two Dimensions	Three Dimensions
Scalar	$1 = 1^0$	$1 = 2^0$	$1 = 3^0$
Vector	$1 = 1^1$	$2 = 2^1$	$3 = 3^1$
Stress	$1 = 1^2$	$4 = 2^2$	$9 = 3^2$

Stress Element

- Stress element is an imaginary object that helps us visualize stress at a point by constructing surfaces that have outward normal in the coordinate directions.

Construction of a Stress Element for Axial Stress

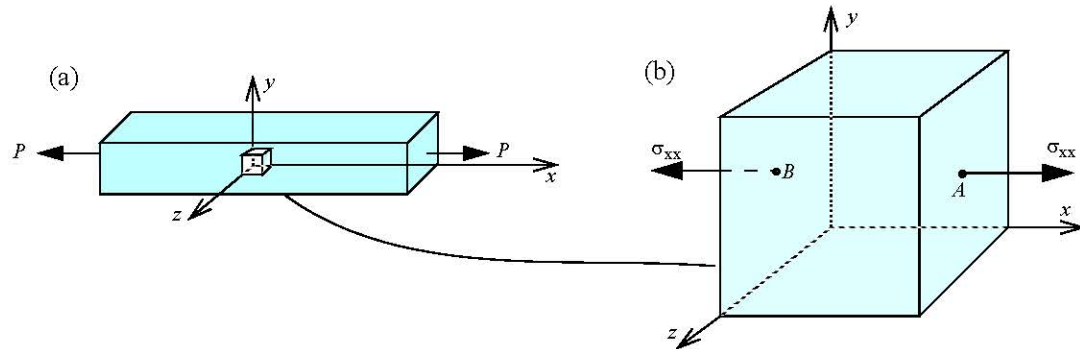

Stress components are distributed forces on a surface.

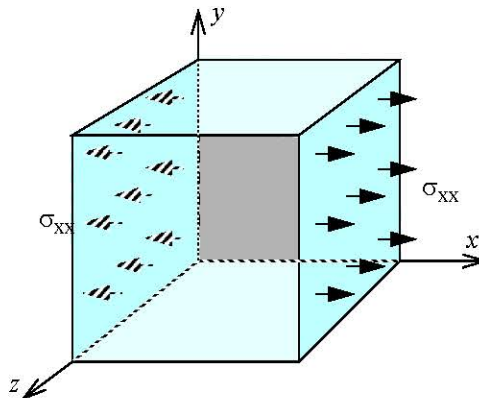

Construction of a Stress Element for Plane Stress:

All stress components on a plane are zero

$$\begin{bmatrix} \sigma_{xx} & \tau_{xy} & 0 \\ \tau_{yx} & \sigma_{yy} & 0 \\ 0 & 0 & 0 \end{bmatrix}$$

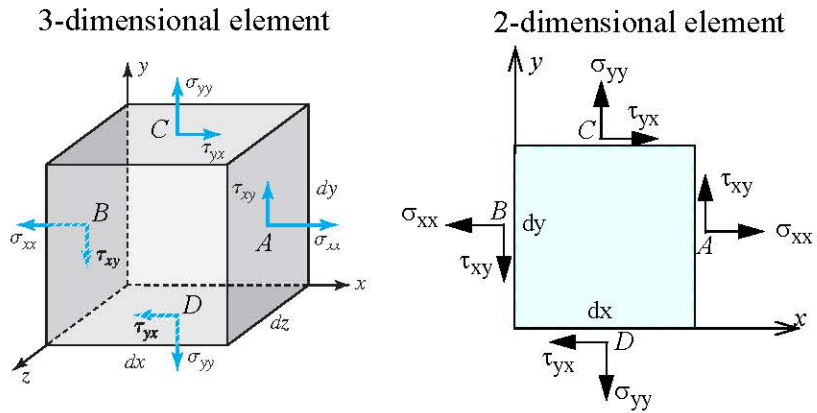

Symmetric Shear Stresses: $\tau_{xy} = \tau_{yx}$ $\tau_{yz} = \tau_{zy}$ $\tau_{zx} = \tau_{xz}$

- A pair of symmetric shear stress points towards the corner or away from the corner.

Stress cube showing all positive stress components

$$\begin{bmatrix} \sigma_{xx} & \tau_{xy} & \tau_{xz} \\ \tau_{yx} & \sigma_{yy} & \tau_{yz} \\ \tau_{zx} & \tau_{zy} & \sigma_{zz} \end{bmatrix}$$

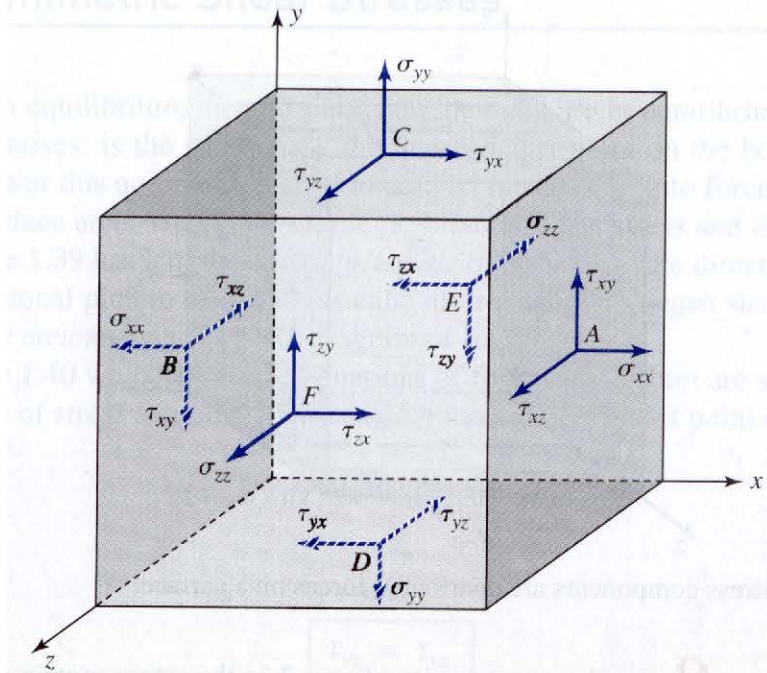

C1.6 Show the non-zero stress components on the A,B, and C faces of the cube.

$$\left[\begin{array}{lll} \sigma_{xx} = 90MPa(C) & \tau_{xy} = -200MPa & \tau_{xz} = 0 \\ \tau_{yx} = -200MPa & \sigma_{yy} = 175MPa(C) & \tau_{yz} = 225MPa \\ \tau_{zx} = 0 & \tau_{zy} = 225MPa & \sigma_{zz} = 150MPa(T) \end{array} \right]$$

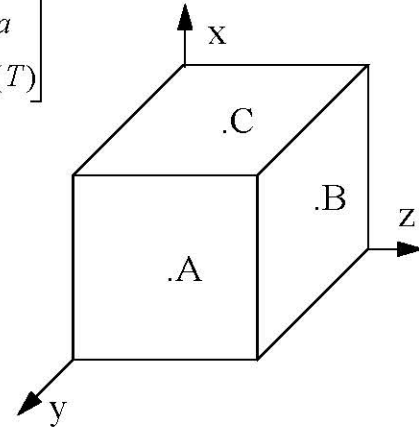

Class Problem 1.2

Show the non-zero stress components of problem C1.6 on the A,B, and C faces of the cube below.

$$\left[\begin{array}{lll} \sigma_{xx} = 90MPa(C) & \tau_{xy} = -200MPa & \tau_{xz} = 0 \\ \tau_{yx} = -200MPa & \sigma_{yy} = 175MPa(C) & \tau_{yz} = 225MPa \\ \tau_{zx} = 0 & \tau_{zy} = 225MPa & \sigma_{zz} = 150MPa(T) \end{array} \right]$$

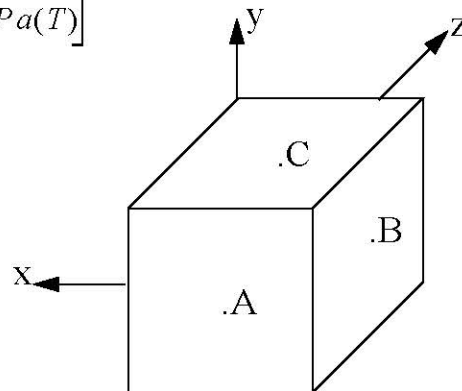

C1.7 Show the non-zero stress components in the r , θ , and x cylindrical coordinate system on the A, B, and C faces of the stress element shown.

$$\begin{bmatrix} \sigma_{rr} = 145MPa(C) & \tau_{r\theta} = 100MPa & \tau_{rx} = -125MPa \\ \tau_{\theta r} = 100MPa & \sigma_{\theta\theta} = 160MPa(T) & \tau_{\theta x} = 165MPa \\ \tau_{xr} = -125MPa & \tau_{x\theta} = 165MPa & \sigma_{xx} = 150MPa(T) \end{bmatrix}$$

